

AST

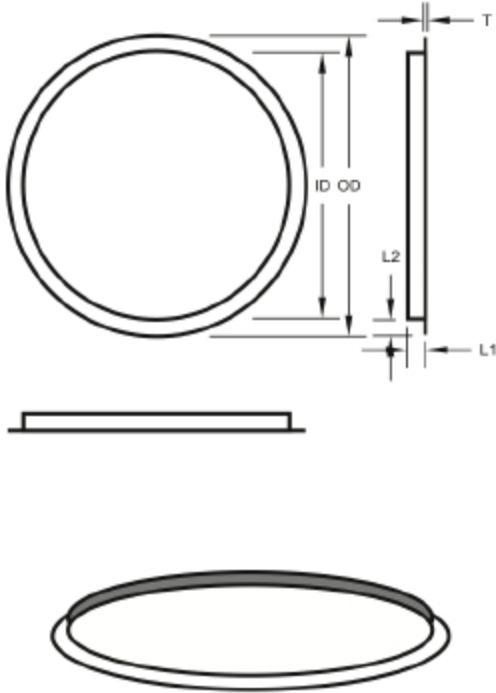

Angle Face Rings



SIZE	DIMENSIONS			
	PIPE SIZE		TUBE SIZE	
IPS / OD	ID	OD	ID	OD
1/2	0.87	1 3/4	.53	1 3/4
3/4	1.08	2 1/8	.78	2 1/8
1	1.35	2 1/2	1.03	2 1/2
1 1/4	1.69	2 3/4	1.28	2 3/4
1 1/2	1.95	2 7/8	1.56	2-7/8
2	2.41	3 1/2	2.06	3 1/2
2 1/2	2.93	4 1/2	2.56	4 1/2
3	3 9/16	5	3 1/16	5
4	4 9/16	6 1/2	4 1/16	6 1/2
6	6 11/16	8 1/2	6 1/16	8 1/2
8	8 11/16	10 11/16	8 1/16	10 11/16
10	10 13/16	12 13/16	10 1/16	12 1/16
12	12 13/16	15 13/16	12 1/16	15 1/16
14			14 1/16	17 1/16
16			16 1/16	19 1/16
18			18 1/16	21 1/16
20			20 1/16	23 1/16
24			24 1/16	28 1/16
30			30 1/8	34 1/8
36			36 1/8	41 1/8
42			42 3/16	47 3/16
48			48 3/16	53 3/16

- Manufactured to the specs and tolerances of ASTM A774.
- Available in 304L, 316L, 317L, or other materials upon request.
- Dimensions shown are typical, but can vary by manufacturer and by customer requirement.
- Other sizes (5, 22,26,54,60,72, etc) available. Call for details.
- Rolled angle face rings are formed and welded using ASTM A276 stainless steel angle.