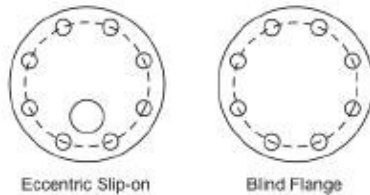
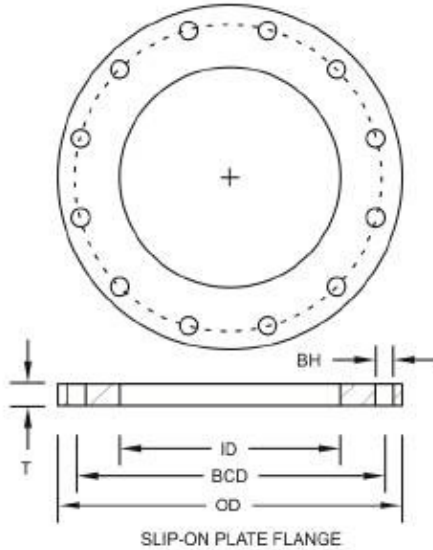
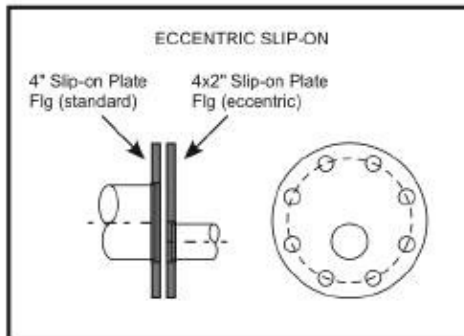

Plate Flanges



Available options:
 Blind flanges
 Metric (DIN) bolt patterns
 Reducing slip-on flange
 Eccentric slip-on flange
 Facing one side for gasket seal
 Backup flanges have a 1/4" 45° land on face
 Variety of thicknesses down to 1/4" thk



PIPE SIZE	OD	ID	T	No. of BH	BH	BCD
2	6	2-7/16	1/2	4	3/4	4-3/4
2-1/2	7	2-15/16	1/2	4	3/4	5-1/2
3	7-1/2	3-9/16	1/2	4	3/4	6
3-1/2	8-1/2	4-1/16	1/2	8	3/4	7
4	9	4-9/16	1/2	8	3/4	7-1/2
5	10	5-5/8	1/2	8	7/8	8-1/2
6	11	6-11/16	1/2	8	7/8	9-1/2
8	13-1/2	8-11/16	1/2	8	7/8	11-3/4
10	16	10-13/16	1/2	12	1	14-1/4
12	19	12-13/16	1/2	12	1	17

TUBE SIZE	OD	ID	T	No. of BH	BH	BCD
2	6	2-7/16	1/2	4	3/4	4-3/4
2-1/2	7	2-15/16	1/2	4	3/4	5-1/2
3	7-1/2	3-9/16	1/2	4	3/4	6
3-1/2	8-1/2	4-1/16	1/2	8	3/4	7
4	9	4-9/16	1/2	8	3/4	7-1/2
5	10	5-5/8	1/2	8	7/8	8-1/2
6	11	6-11/16	1/2	8	7/8	9-1/2
8	13-1/2	8-11/16	1/2	8	7/8	11-3/4
10	16	10-13/16	1/2	12	1	14-1/4
12	19	12-13/16	1/2	12	1	17
14	21	14-1/16	1/2	12	1-1/8	18-3/4
16	23-1/2	16-1/16	1/2	16	1-1/8	21-1/4
18	25	18-1/16	1/2	16	1-1/4	22-3/4
20	27-1/2	20-1/16	1/2	20	1-1/4	25
24	32	24-1/16	1/2	20	1-3/8	29-1/2
30	38-3/4	30-3/32	1/2	28	1-3/8	36
36	46	36-3/32	1/2	32	1-5/8	42-3/4

- Manufactured from ASTM A240 stainless steel plate.
- Alloys available include 304L, 316L, 317L, carbon steel; others upon request.
- Slip-on plate flange welds directly to pipe/tube.
- Back-up [plate] flange is used in conjunction with an angle face ring, flat face ring, or stub end to form a "VanStone" joint allowing the flange infinite positioning as it spins freely behind the ring/stub-end; (see back-up flange).